



## Magneto-resistive Sensors

Series 300 • 20 - NPN

Series 300 • 10 - PNP

Housing M12 x 1

- Housing material: stainless steel VA
- Flush mountable
- Sensing distance Sn 1.5 mm

Certificate:



### Technical data

Operating distance Sn [mm], flush mounting	1.5, yes
Electrical version	3-wire DC
Output	NO
<b>Type NPN</b>	<b>MRS-300-M12-20-S</b>
<b>Art.-No.</b>	<b>360 300</b>
<b>Connection diagram No.</b>	<b>1</b>
<b>Type PNP</b>	<b>MRS-300-M12-10-S</b>
<b>Art.-No.</b>	<b>360 100</b>
<b>Connection diagram No.</b>	<b>4</b>
Operating voltage ( $U_B$ )	10...35 V DC
Output current max. ( $I_o$ )	250 mA
Load current min.	-
Voltage drop max. ( $U_d$ )	$\leq 2.5$ V
Permitted residual ripple max.	10 %
No-load current ( $I_o$ )	typ. 15 mA
Frequency of operating cycles min./max.	0.5 Hz/15 kHz
Permitted ambient temperature	-40...+125°C
LED-display	yellow
Protective circuit	built-in
Degree of protection IEC 529	IP 67
Connection cable	2 m 3 x 0.14 mm <sup>2</sup>
Housing material	VA No. 1.4305
Active surface	VA No. 1.4305
Lid	PEEK

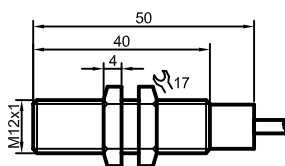

1

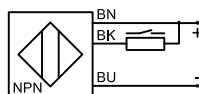

2

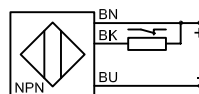

3

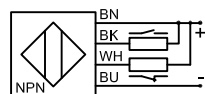

4

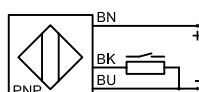

5

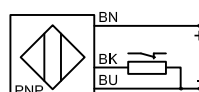

6

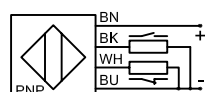

All specifications are subject to change without notice. (05/2004)



## Magneto-resistive Sensors

Series 300 • 20 - NPN

Series 300 • 10 - PNP

Housing M12 x 1

- Housing material: PA
- Flush mountable
- Sensing distance Sn 1.5 mm



Certificate:

### Technical data

Operating distance Sn [mm], flush mounting	1.5, yes
Electrical version	3-wire DC
Output	NO
<b>Type NPN</b>	<b>MRS-300-M12-20-S-K</b>
<b>Art.-No.</b>	<b>360 350</b>
<b>Connection diagram No.</b>	<b>1</b>
<b>Type PNP</b>	<b>MRS-300-M12-10-S-K</b>
<b>Art.-No.</b>	<b>360 150</b>
<b>Connection diagram No.</b>	<b>4</b>
Operating voltage ( $U_B$ )	10...35 V DC
Output current max. ( $I_o$ )	250 mA
Load current min.	-
Voltage drop max. ( $U_d$ )	$\leq 2.5$ V
Permitted residual ripple max.	10 %
No-load current ( $I_o$ )	typ. 15 mA
Frequency of operating cycles min./max.	0.5 Hz/15 kHz
Permitted ambient temperature	-25...+70°C
LED-display	yellow
Protective circuit	built-in
Degree of protection IEC 529	IP 67
Connection cable	2 m 3 x 0.14 mm <sup>2</sup>
Housing material	PA
Active surface	PA
Lid	PA

All specifications are subject to change without notice. (05/2004)

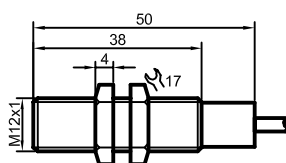

1

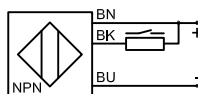

2

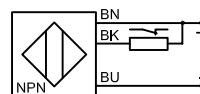

3

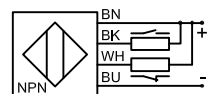

4

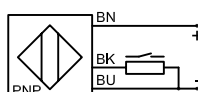

5

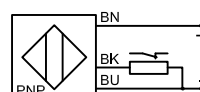

6

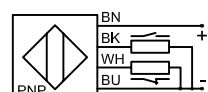



## Magneto-resistive Sensors

### Series 300 • 2-wire

#### Housing M12 x 1

- Housing material: PA
- Flush mountable
- Sensing distance  $S_n$  1.5 mm

Certificate:



#### Technical data

Operating distance $S_n$ [mm], flush mounting	1.5, yes
Electrical version	2-wire DC
Output	NO
<b>Type</b>	<b>MRS-300-M12-N-K</b>
<b>Art.-No.</b>	<b>362 100</b>
<b>Connection diagram No.</b>	<b>see below</b>
Operating voltage ( $U_b$ )	7.5...20 V DC
Output current active surface free	typ. 7 mA
Output current active surface covered	typ. 14 mA
Self-inductance (L)	100 $\mu$ H
Self-capacitance (C)	500 pF
Voltage drop max. ( $U_d$ )	$\leq 2.5$ V
Permitted residual ripple max.	10 %
No-load current ( $I_0$ )	typ. 7 mA
Frequency of operating cycles max.	0.5 Hz/15 kHz
Permitted ambient temperature	-25...+70°C
LED-display	yellow
Protective circuit	built-in
Degree of protection IEC 529	IP 67
Connection cable	2 m 2 x 0.14 mm <sup>2</sup>
Housing material	PA
Active surface	PA
Lid	PA

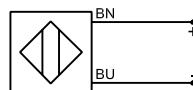
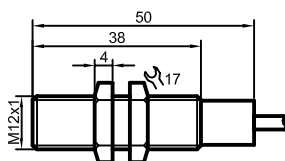

All specifications are subject to change without notice. (05/2004)



## Magneto-resistive Sensors

Series 300 • 20 - NPN

Series 300 • 10 - PNP

Housing M18 x 1

- Housing material: stainless steel VA

- Flush mountable

- Sensing distance Sn 3 mm

Certificate:



### Technical data

Operating distance Sn [mm], flush mounting	3, yes
Electrical version	3-wire DC
Output	NO
<b>Type NPN</b>	<b>MRS-300-M18-20-S</b>
<b>Art.-No.</b>	<b>360 700</b>
<b>Connection diagram No.</b>	<b>1</b>
<b>Type PNP</b>	<b>MRS-300-M18-10-S</b>
<b>Art.-No.</b>	<b>360 500</b>
<b>Connection diagram No.</b>	<b>4</b>
Operating voltage ( $U_B$ )	10...35 V DC
Output current max. ( $I_o$ )	250 mA
Load current min.	-
Voltage drop max. ( $U_d$ )	$\leq 2.5$ V
Permitted residual ripple max.	10 %
No-load current ( $I_o$ )	typ. 15 mA
Frequency of operating cycles min./max.	0.5 Hz/15 kHz
Permitted ambient temperature	-40...+125°C
LED-display	yellow
Protective circuit	built-in
Degree of protection IEC 529	IP 67
Connection cable	2 m 3 x 0.34 mm <sup>2</sup>
Housing material	VA No. 1.4404
Active surface	VA No. 1.4404
Lid	PEEK

All specifications are subject to change without notice. (05/2004)

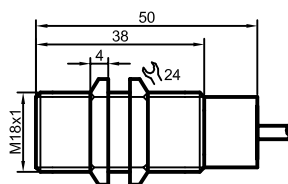

1

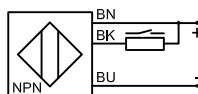

2

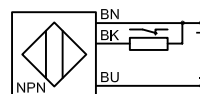

3

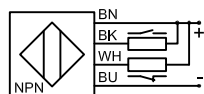

4

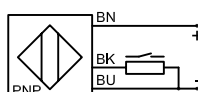

5

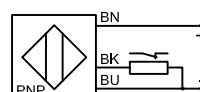

6

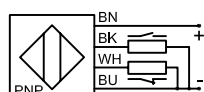



**Magneto-resistive Sensors  
with detection of direction of rotation**  
**Series 350 • 20 - NPN**  
**Series 350 • 10 - PNP**

- Housing M12 x 1**
- Housing material: stainless steel VA
  - Flush mountable
  - Sensing distance Sn 1 mm

Certificate::



**Technical data**

Operating distance Sn [mm], flush mounting	1, yes
Electrical version	4-wire DC
Output	NO
<b>Type NPN</b>	<b>MRS-350-M12-20-S</b>
<b>Art.-No.</b>	<b>361 100</b>
<b>Connection diagram No.</b>	<b>1</b>
<b>Type PNP</b>	<b>MRS-350-M12-10-S</b>
<b>Art.-No.</b>	<b>360 900</b>
<b>Connection diagram No.</b>	<b>4</b>
Operating voltage (U <sub>B</sub> )	10...35 V DC
Output current max. (I <sub>O</sub> )	2 x 250 mA
Load current min.	-
Voltage drop max. (U <sub>d</sub> )	≤ 2.5 V
Permitted residual ripple max.	10 %
No-load current (I <sub>0</sub> )	typ. 15 mA
Frequency of operating cycles min./max.	0.5 Hz/10 kHz
Permitted ambient temperature	-40...+125°C
LED-display	green/yellow
Protective circuit	built-in
Degree of protection IEC 529	IP 67
Connection cable	2 m 4 x 0.14 mm <sup>2</sup>
Housing material	VA No. 1.4305
Active surface	VA No. 1.4305
Lid	PEEK

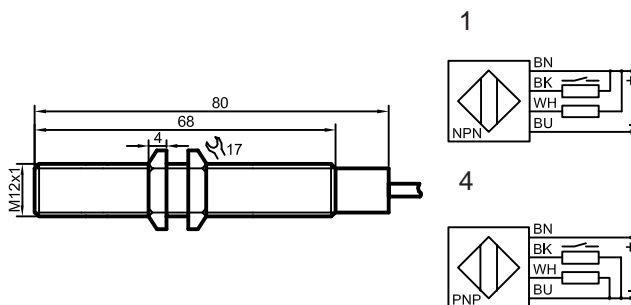

BK = Speed control  
 WH = detection of direction of rotation

All specifications are subject to change without notice. (05/2004)



**Magneto-resistive Sensors**  
with detection of direction of rotation  
**Series 350 • 20 - NPN**  
**Series 350 • 10 - PNP**

**Housing M18 x 1**

- Housing material: stainless steel VA
- Flush mountable
- Sensing distance Sn 2.5 mm

Certificate:



**Technical data**

Operating distance Sn [mm], flush mounting	2,5, yes
Electrical version	4-wire DC
Output	NO
<b>Type NPN</b>	<b>MRS-350-M18-20-S</b>
<b>Art.-No.</b>	<b>361 500</b>
<b>Connection diagram No.</b>	<b>1</b>
<b>Type PNP</b>	<b>MRS-350-M18-10-S</b>
<b>Art.-No.</b>	<b>361 300</b>
<b>Connection diagram No.</b>	<b>4</b>
Operating voltage ( $U_B$ )	10...35 V DC
Output current max. ( $I_o$ )	2 x 250 mA
Load current min.	-
Voltage drop max. ( $U_o$ )	$\leq 2.5$ V
Permitted residual ripple max.	10 %
No-load current ( $I_o$ )	typ. 15 mA
Frequency of operating cycles min./max.	0.5 Hz/10 kHz
Permitted ambient temperature	-40...+125°C
LED-display	green/yellow
Protective circuit	built-in
Degree of protection IEC 529	IP 67
Connection cable	2 m 4 x 0.34 mm <sup>2</sup>
Housing material	VA No. 1.4404
Active surface	VA No. 1.4404
Lid	PEEK

All specifications are subject to change without notice. (05/2004)

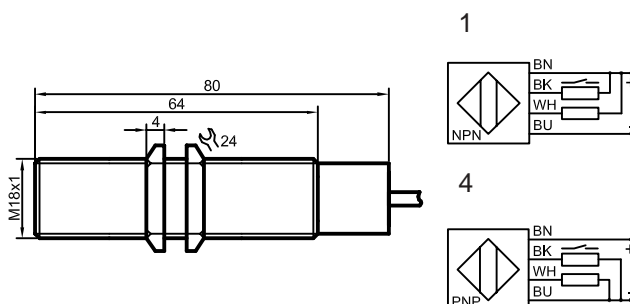

BK = Speed control  
WH = detection of direction of rotation



## Magneto-resistive Sensors with detection of direction of rotation

### Series 350 • 10 - PNP

#### Housing M12 x 1

- Housing material: stainless steel VA
- Flush mountable
- Sensing distance Sn 1 mm
- With dephased output signal

Certificate:



#### Technical data

Operating distance Sn [mm], flush mounting	1, yes
Electrical version	4-wire DC
Output	NO
<b>Type NPN</b>	
<b>Art.-No.</b>	
<b>Connection diagram No.</b>	
<b>Type PNP</b>	
<b>Art.-No.</b>	
<b>Connection diagram No.</b>	
Operating voltage ( $U_B$ )	10...35 V DC
Output current max. ( $I_o$ )	2 x 250 mA
Load current min.	-
Voltage drop max. ( $U_d$ )	$\leq 2.5$ V
Permitted residual ripple max.	10 %
No-load current ( $I_o$ )	typ. 15 mA
Frequency of operating cycles min./max.	0.5 Hz/10 kHz
Permitted ambient temperature	-40...+125°C
LED-display	green/yellow
Protective circuit	built-in
Degree of protection IEC 529	IP 67
Connection cable	2 m 4 x 0.14 mm <sup>2</sup>
Housing material	VA No. 1.4305
Active surface	VA No. 1.4305
Lid	PEEK

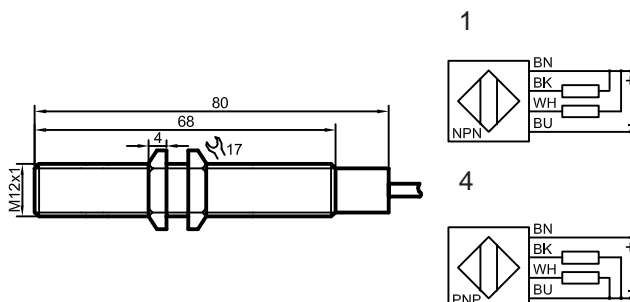

BK = Speed control  
WH = detection of direction of rotation dephased

All specifications are subject to change without notice. (05/2004)



**Magneto-resistive Sensors  
with detection of direction of rotation**

**Series 350 • 10 - PNP**

**Housing M18 x 1**

- Housing material: stainless steel VA
- Flush mountable
- Sensing distance Sn 2.5 mm
- With dephased output signal

Certificate:



**Technical data**

Operating distance Sn [mm], flush mounting	2.5, yes
Electrical version	4-wire DC
Output	NO
<b>Type NPN</b>	
<b>Art.-No.</b>	
<b>Connection diagram No.</b>	
<b>Type PNP</b>	<b>MRS-350-M18-10-Z</b>
<b>Art.-No.</b>	<b>361 430</b>
<b>Connection diagram No.</b>	<b>4</b>
Operating voltage (U <sub>B</sub> )	10...35 V DC
Output current max. (I <sub>o</sub> )	2 x 250 mA
Load current min.	-
Voltage drop max. (U <sub>v</sub> )	≤ 2.5 V
Permitted residual ripple max.	10 %
No-load current (I <sub>o</sub> )	typ. 15 mA
Frequency of operating cycles min./max.	0.5 Hz/10 kHz
Permitted ambient temperature	-40...+125°C
LED-display	green/yellow
Protective circuit	built-in
Degree of protection IEC 529	IP 67
Connection cable	2 m 4 x 0.34 mm <sup>2</sup>
Housing material	VA No. 1.4404
Active surface	VA No. 1.4404
Lid	PEEK

All specifications are subject to change without notice. (05/2004)

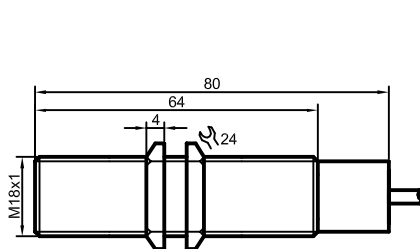

1

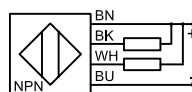

4

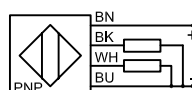

BK = Speed control  
WH = detection of direction of rotation dephased



## NORMS

The products of Rechner Industrie-Elektronik GmbH are designed and checked in accordance with the standards and specifications, DIN - VDE - IEC, for electric and electronic instruments. For new and revised products the newest standards are always used.

Effective standards for proximity switches and sensors:

*DIN VDE 0660 Part 208:*

Low-voltage switchgear - additional requirements for inductive proximity switches.

*DIN VDE 0660 Part 209*

Low-voltage switchgear and controlgear, control switches - additional requirements for proximity switches used in safety-related applications.

*DIN VDE 0660 Part 212* (Replaces DIN 19234)

Instrumentation and control technology - electrical position sensors - DC interface for position sensors and switching amplifiers

European Standards

*EN 60947-5-2 Low Voltage Switchgear Part 5*

Control circuit devices and switching elements, section 2: proximity switches

*EN 60947-5-6*

Control circuit devices and switching elements, proximity sensors - DC interface for proximity sensors and switching amplifiers (NAMUR)

International Standards

*IEC 947-5-2 Low-voltage switchgear and controlgear Part 5*

Control circuit devices and switching elements - Section 2, proximity switches

*Draft IEC 61934*

Control circuit devices and switching elements DC interface for proximity sensors and switching amplifiers (NAMUR)

Standards On Explosion Protection

*DIN EN 50014*

Electrical apparatus for potentially explosive environments.  
General requirements.

*DIN EN 50020*

Electrical apparatus for potentially explosive environments.  
Intrinsic safety „i“

*EN 60079-10*

Electrical apparatus for potentially explosive environments.  
Classification of hazardous areas.

*EN 60079-14*

Electrical apparatus for potentially explosive environments.  
Classification of hazardous areas (mines excepted).

# NORMS

Normen zur Qualitätssicherung (QS)

*DIN ISO 9000-9004 (EN 29000-29 004)*  
Quality assurance (QA) for products and services

*DIN ISO 9001*  
Quality assurance in design/development, production, installation and servicing

*DIN ISO 9002*  
Quality assurance in production

*DIN ISO 9003*  
Quality assurance for final testing only

*DIN ISO 9004*  
Quality management and elements of a quality management system

RECHNER Industrie-Elektronik-GmbH is certified according to DIN ISO 9001:2000.

## CE - Marking

The CE marking represents the manufacturer's confirmation that the identified product conforms to applicable standards and directives throughout Europe. The following regulations apply to the RECHNER products.

*89/336/EWG*  
EMC Directive (EN 60 947-5-2)

*73/23/EWG*  
Low-voltage Directive (compare with VDE 0160, product standard EN 60947-5-2)

*Directive 94/9/EG*  
Equipment and Protection Systems designed for use in potentially explosive environments

RECHNER Industrie-Elektronik GmbH certifies the conformity of its products with each of the applicable directives in a Manufacturer's Declaration. In addition RECHNER has a laboratory accredited by DATech for testings according to IEC/EN 60947-5-2 and also an accredited EMC laboratory.

All specifications are subject to change without notice. (05/2004)

## TYPE SELECTION IN ARTICLE NUMBER ORDER

Art.-No.	Type Description	Page
360100	MRS-300-M12-10-S	12
360150	MRS-300-M12-10-S-K	13
360300	MRS-300-M12-20-S	12
360350	MRS-300-M12-20-S-K	13
360500	MRS-300-M18-10-S	15
360700	MRS-300-M18-20-S	15
360900	MRS-350-M12-10-S	16
360950	MRS-350-M12-10-Z	18
361100	MRS-350-M12-20-S	16
361300	MRS-350-M18-10-S	17
361430	MRS-350-M18-10-Z	19
361500	MRS-350-M18-20-S	17
362100	MRS-300-M12-N-K	14

## TYPE SELECTION IN TYPE DESCRIPTION ORDER

Type Description	Art.-No.	Page
MRS-300-M12-10-S	360100	12
MRS-300-M12-10-S-K	360150	13
MRS-300-M12-20-S	360300	12
MRS-300-M12-20-S-K	360350	13
MRS-300-M12-N-K	362100	14
MRS-300-M18-10-S	360500	15
MRS-300-M18-20-S	360700	15
MRS-350-M12-10-S	360900	16
MRS-350-M12-10-Z	360950	18
MRS-350-M12-20-S	361100	16
MRS-350-M18-10-S	361300	17
MRS-350-M18-10-Z	361430	19
MRS-350-M18-20-S	361500	17

All specifications are subject to change without notice. (05/2004)